

SURFACE PLANERS

FOR USE ONLY IN SECURELY MOUNTED MACHINES.
CARE SHOULD BE TAKEN WITH SPEED SELECTION.

3 Flute

All sizes in millimetres

Part No.	D	B	L	d	INSERT NO.
R3 5512 1/2	55	12	78	12.7	PL 12 12 1.5

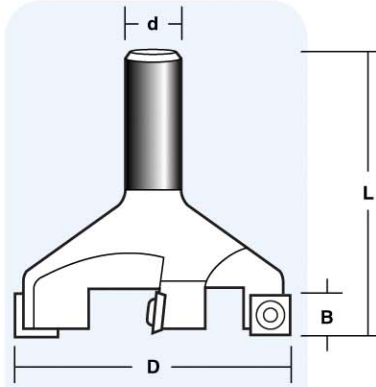

4 Flute

All sizes in millimetres

Part No.	D	B	L	d	INSERT NO.
R4 8012 16M	80	12	82	16	PL 12 12 1.5
R4 8012 20M	80	12	82	20	PL 12 12 1.5

MULTI-SHAPE PROFILE BIT

Use the standard range of shapes available or custom design your own shape.

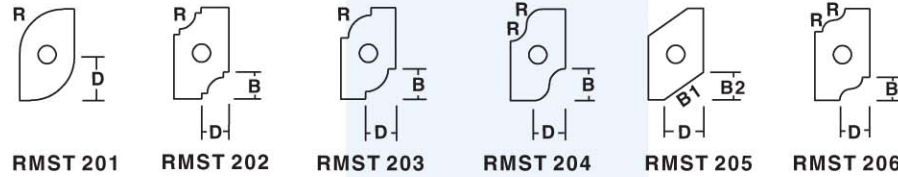
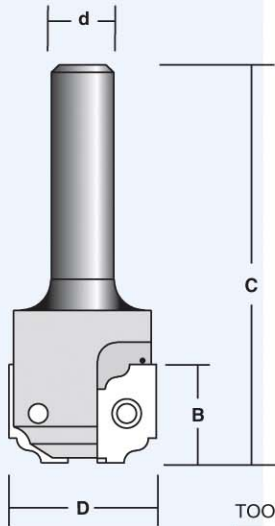

RMST 201 RMST 202 RMST 203 RMST 204 RMST 205 RMST 206

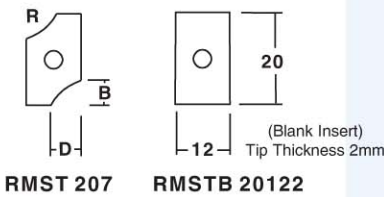

RMST 207 RMSTB 20122

INSERTS

PART No.	B mm	B1 mm	B2 mm	R mm	chmf	D mm
RMST 201	9.52			9.52		
RMST 202	5.9			3.5		5.9
RMST 203	6.6			5.0		6.6
RMST 204	7.0			3.5		7.0
RMST 205		10.45	6.01		35°	8.58
RMST 206	5.0			2.5		6.6
RMST 207	5.5			11.68		6.7

TOOL - 2 FLUTE (without inserts)

PART No.	D mm	B mm	L mm	d mm
RMS 200 1/2	30	20	75	12.7

Replacement Insert - 20 x 12 x 2.0

Replacement Screw - M4

Replacement Torx Key - T15

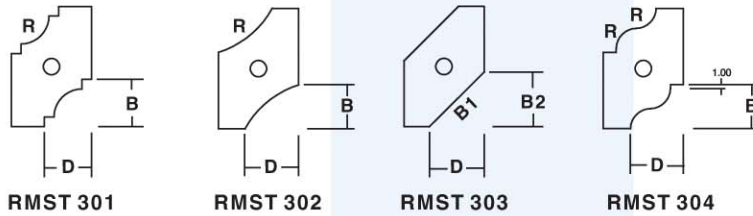
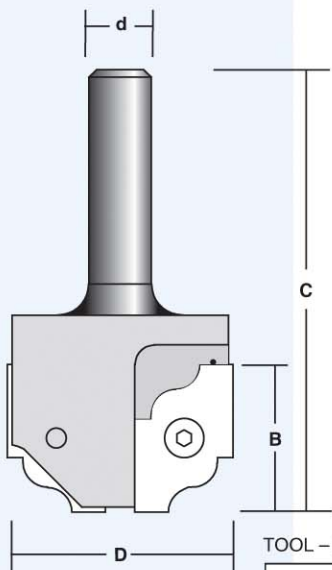

RMST 301 RMST 302 RMST 303 RMST 304

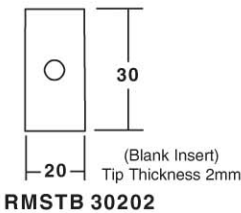

RMSTB 30202

INSERTS

PART No.	B mm	B1 mm	B2 mm	R mm	chmf	D mm
RMST 301	11.8			7		11.8
RMST 302	11			23.35		13.47
RMST 303		19.25	13.61		45°	13.61
RMST 304	11			5		13.2

TOOL - 2 FLUTE (without inserts)

PART No.	D mm	B mm	L mm	d mm
RMS 300 1/2	46	30	90	16
RMS 300 16	46	30	90	16

Replacement Insert - 30 x 20 x 2.0

Replacement Screw - M4

Replacement Torx Key - T15

