

BATTEN MOULD BIT

A bit to enable production of batten moulding for the fixing of cement sheeting and other types of wall panelling.

CARBIDE TIPPED - TWO FLUTES WITH BALL BEARING GUIDE
12.7 mm (1/2") SHANK

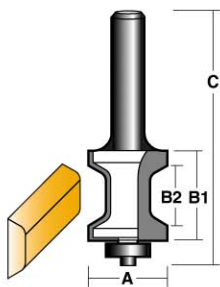

PART No.	A		B1		B2		C	
	in.	mm	in.	mm	in.	mm	in.	mm
TBM 33 B 1/2	1-1/8	28.6	1.3	33	7/8	22.2	3-5/8	92

Replacement Ball Bearing TB8.

TABLE EDGE BIT

A popular bit for finishing table edges.

CARBIDE TIPPED - TWO FLUTES WITH BALL BEARING GUIDE
12.7 mm (1/2") SHANK

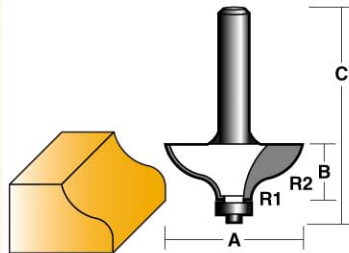

PART No.	A		B		C		R1 RADIUS	R2 RADIUS
	in.	mm	in.	mm	in.	mm	mm	mm
TEB 14 B 1/2	2	50.8	0.720	18.3	3-1/8	79	8	16

Replacement Ball Bearing TB11.

TABLE EDGE BIT WITH RETURN

This bit has a return to round over bottom of table for an attractive finish.

NEW

CARBIDE TIPPED - TWO FLUTES WITH BALL BEARING GUIDE
12.7 mm (1/2") SHANK

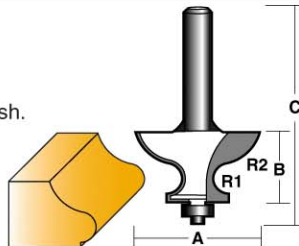

PART No.	A		B		C		R1 RADIUS	R2 RADIUS
	in.	mm	in.	mm	in.	mm	mm	mm
TEB 15 B 1/2	2	50.8	1 5/16	33.5	-	94.7	6.35	16
TEB 16 B 1/2	2	50.8	-	36.7	3-27/32	97.6	8	16

Replacement Ball Bearing TB11.

DOUBLE EDGE RADIUS BIT

This versatile assembly enables you to round the top and bottom edges of timber at the same time. Assembly comes with bearing, spacer and washers, which allow you to cut up to 30mm material.

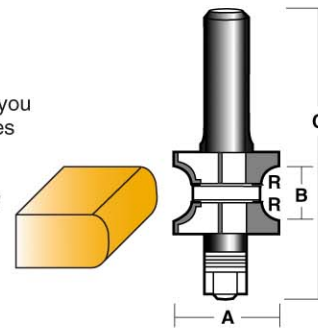

CARBIDE TIPPED - FOUR FLUTES WITH BALL BEARING GUIDE
12.7 mm (1/2") SHANK

PART No.	A	B	C	R RADIUS
	mm	mm	mm	mm
TDA 194-3 MB 1/2	28	15-32	97.8	3
TDA 194-5 MB 1/2	32	19-36	97.8	5
TDA 194-8 MB 1/2	38	25-39	97.8	8

CUTTER ONLY

	A	B	C	R RADIUS
T 194-3 M RH	28	Cutter only - Top		3
T 194-3 M LH	28	Cutter only - Bottom		3
T 194-5 M RH	32	Cutter only - Top		5
T 194-5 M LH	32	Cutter only - Bottom		5
T 194-8 M RH	38	Cutter only - Top		8
T 194-8 M LH	38	Cutter only - Bottom		8

Wood Thickness	Spaces between cutters
10	nil (no Brg.)
19	Brg. + 2 Washers
22	Brg. + 5 Washers
25	Brg. + Spacer
30	Brg. + Spacer & 5 Washers

Replacement Ball Bearing TB12.
Replacement Arbor TA20.

SPECIAL BITS

Are made to any size or detail.
Please furnish a wood sample, drawing or dimensioned sketch when ordering.

SOLID SURFACE BITS

COUNTER TOP BIT

NO DRIP DESIGN
TWO FLUTES - WITH CARBI-SMOOTH BEARING ASSEMBLY & BALL BEARING GUIDE
12.7 mm (1/2") SHANK

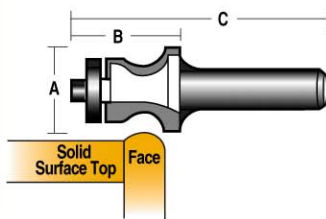

PART No.	A	B	C
TSS 1 B 1/2	25.4	22.9	82

Replacement Bearing Assembly TBT21.

COUNTER TOP BIT

NO DRIP DESIGN - TWO FLUTES
SUFFIX 1/2 = 1/2" SHANK, OTHERWISE 1/4"

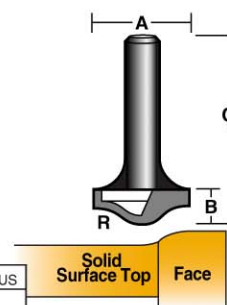

PART No.	A	B	C	R RADIUS
TSS 2	19	9.3	41	6.35
TSS 2 1/2	19	9.3	54	6.35

COUNTER TOP BIT

Used in conjunction with TSS 2 and TSS 2 1/2

TWO FLUTES - WITH CARBI-SMOOTH BEARING ASSEMBLY & BALL BEARING GUIDE
SUFFIX 1/2 = 1/2" SHANK, OTHERWISE 1/4"

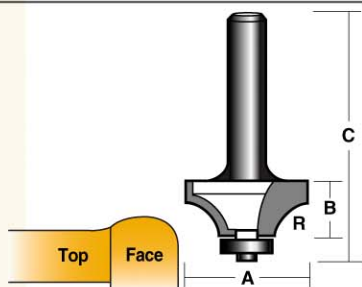

PART No.	A	B	C	R RADIUS
TSS 3 B	28.6	13.5	60	6.35
TSS 3 B 1/2	28.6	13.5	73	6.35

Replacement Bearing Assembly TBT20.

BEVEL UNDERMOUNT BOWL BIT

TWO FLUTES - WITH CARBI-SMOOTH BEARING ASSEMBLY & BALL BEARING GUIDE
12.7 mm (1/2") SHANK

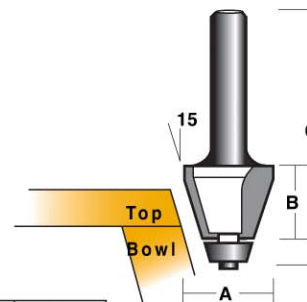

PART No.	A	B	C
TSS 4 B 1/2	35	32	88

Replacement Bearing Assembly TBT19.

